

AD103C

Digital Transducer
Electronics

Amplifier board AD103C

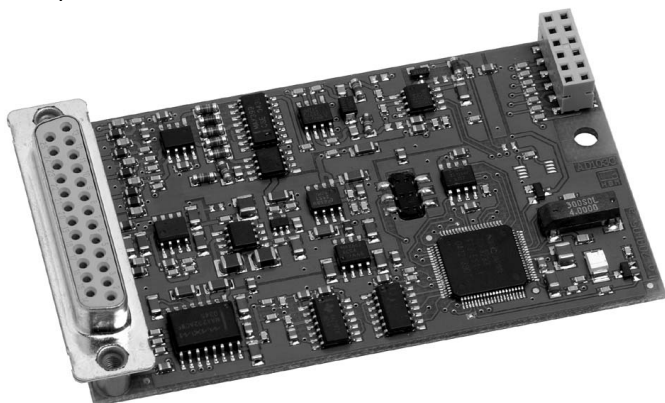

Special features

- DC Amplifier for resistive transducers
- For static and dynamic applications
- Direct computer connection via RS-232 interface
- Test report for 10 000 d, 0.5 $\mu\text{V/e}$, class III accord. to OIML in preparation
- High transmission rate and resolution
- Memory for user settings
- Command set for filling and dosing functions

Functional diagram

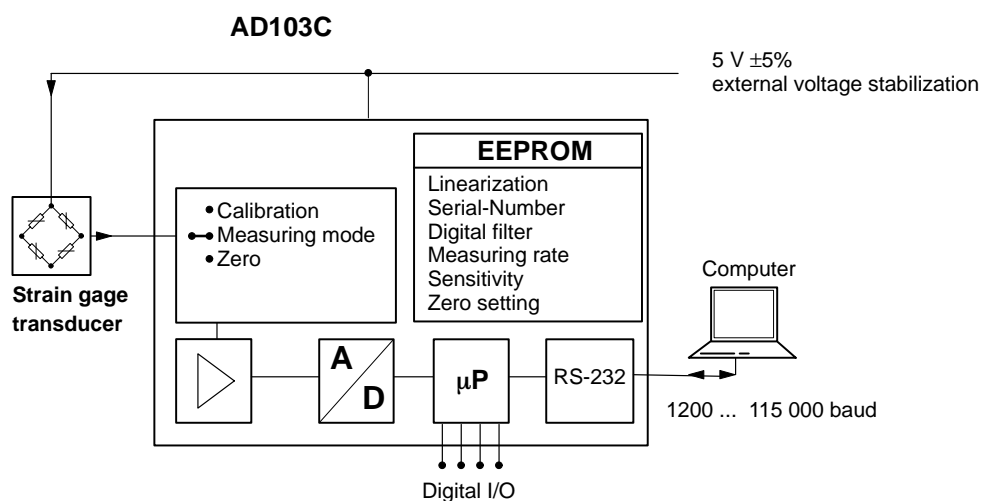

Specifications

Type	AD103C	
Accuracy class	0.01	
Number of trade values, accord. to EN 45 501 (R76)	e	10 000
Input sensitivity	$\mu\text{V}/\text{e}$	0.5
Measuring range	mV/V	± 2.0
Input signal range, max.		± 3.0
Measuring signal resolution, max.	Bit	24 (with 1 Hz)
Measuring rate (depending on output format and baud rate)	Hz	1200 ... 4.7
Cutt-off frequency of the digital filter, adjust. (± 3 dB)		200 ... 0.25
Bridge excitation voltage U_B ¹⁾	V_{DC}	$5 \pm 5\%$ (= operating voltage)
Measuring signal input, SG transducer (Full bridge)	Ω	$\geq 40 \dots 4000$ (depending on used basic device)
Transducer connection		6-wire connection
Input resistance (differentiell)	$M\Omega$	> 15
Transducer cable length	m	≤ 100 with calibration incl. cable
Interface cable length RS-232	m	≤ 15 (25-pol. Sub-D-female connector)
Calibration signal	mV/V	$2 \pm 0.01\%$
Temperature stability of the calibration signal	ppm/ $^{\circ}\text{C}$	2.5
Linearity deviation (related to full scale value)	%	± 0.002
Temperature effect on zero point (related to full scale value) measuring sensitivity (related to actual value)	%/10 K	typ. ± 0.0025 ; max. 0.005 typ. ± 0.0025 ; max. 0.005
Interface		RS-232
Baud rate, adjustable	baud	1200 ... 115 000
Operating voltage	V_{DC}	$5 \pm 5\%$ Residual ripple ≤ 10 mV (p.p.)
Current consumption (without load cell) ²⁾	mA	≤ 120
Nominal temperature range		$-10 \dots +40$ [14...104]
Operating temperature range	$^{\circ}\text{C}$ [$^{\circ}\text{F}$]	$-20 \dots +70$ [-4...158]
Storage temperature range		$-40 \dots +85$ [-40...185]
Dimensions (LxWxH)	mm	93 x 53 x 17
Weight, approx.	g	40
Degree of protection to DIN 40050 (IEC 529)		IP00

¹⁾ Excitation from operating voltage

²⁾ Current consumption $\leq 120\text{mA} + \text{Excitation voltage } U_B / \text{Bridge resistance } R_B$

Ordering designation

1-AD103C

Accessories, to be ordered separately

Basic devices

1-AED9101A, 1-AED9201A, 1-AED9301A, 1-AED9401A (see separate Data Sheets), they offer:

- EMC protection
- Degree of protection IP 65
- Operating voltage range 18...30 V
- additional interfaces (RS-485, RS-232, Profibus, CANOpen, DeviceNet)
- galvanic disconnected in-, and outputs

Documentation

- 1-FIT-AED-DOC (CD-ROM with operating manual and AED_Panel32 panel program)

Modifications reserved.

All details describe our products in general form only. They are not to be understood as express warranty and do not constitute any liability whatsoever.

Hottinger Baldwin Messtechnik GmbH

Im Tiefen See 45, D-64293 Darmstadt, Germany

Tel.: +49 6151 803-0 Fax: +49 6151 803 9100

Email: support@hbm.com Internet: www.hbm.com



measurement with confidence