

# P15

## Pressure Gage Transducers for Excess Pressure



### Special features

- P15RVA1: Output 0...10 V
- P15RVA2: Output 4...20 mA (2-wire)
- Optimum price:performance ratio
- Highly reliable
- No liquid filler
- Withstands overloading up to 200 %
- Corrosion-resistant
- Small in size
- High EMC (CE mark)

Dimensions (in mm; 1 mm= 0.03937 inches)

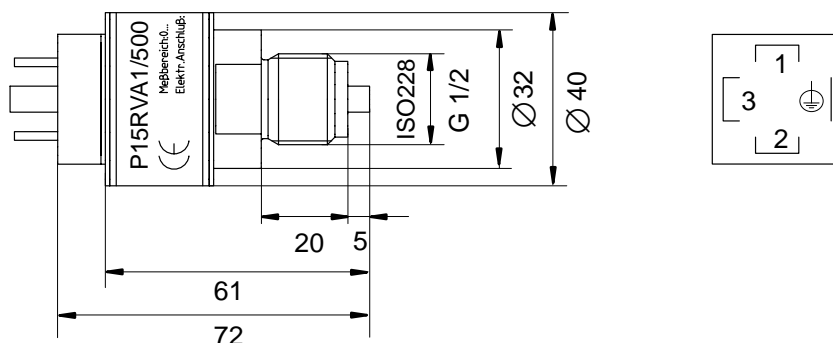

**Cable socket not part of standard supply !**

Measuring range	Order ref. 0...10 V	Order ref. 4...20 mA
0...10 bar	1-P15RVA1/10B	1-P15RVA2/10B
0...20 bar	1-P15RVA1/20B	1-P15RVA2/20B
0...50 bar	1-P15RVA1/50B	1-P15RVA2/50B
0...100 bar	1-P15RVA1/100B	1-P15RVA2/100B
0...200 bar	1-P15RVA1/200B	1-P15RVA2/200B
0...500 bar	1-P15RVA1/500B	1-P15RVA2/500B

1) Pin assignment of standard connector acc. to DIN 43650

Plug assignment <sup>1)</sup>	Type	
	P15RVA1	P15RVA2
1	Supply voltage 18...30 V	Supply voltage 7...30 V, Output 4...20 mA
2	Ground	Ground
3	Output 0...10 V	Not used
⊕	Shield	Shield

## Specifications (in accordance with DIN 16086)

Type	P15RVA1 / P15RVA2						
Class of accuracy	1						
<b>Mechanical input characteristics</b>							
Excess pressure, Measuring range Initial value: ambient air pressure	bar	10	20	50	100	200	500
Fundamental resonance frequency of the membrane	kHz, c.	12	19	29	45	65	85
Overload cutoff at 23 °C [73 °F]	%	200					
Test pressure	%	200					
Destructive range	%	> 200					
Under dynamic loading Permitted pressure	%	100					
Permitted oscillation bandwidth (in accordance with DIN 50 100)	%	70	85	85	95	95	60
Material of parts affected by measurement medium		1.4542 stainless steel					
Dead volume	mm <sup>3</sup>	700					
Change in dead volume	mm <sup>3</sup>	2	2	2	0.6	0.5	0.3
Ambient conditions Rated temperature range Operating temperature range Storage temperature range	°C [°F] °C [°F] °C [°F]	-20...+70 [-5...+160] -25...+70 [-15...+160] -40...+85 [-40...+185]					
Maximum mean temperature if installed horizontally or hanging below i.e. air-cooling at max. ambient temperature of +60 °C [140 °F]	°C [°F]	105 [220]					
Impact resistance (type testing according to DIN IEC 68) Impact acceleration Vibration acceleration (frequency range 10...100 Hz)	m/s <sup>2</sup> m/s <sup>2</sup>	650 150					
EMC (in accordance with IEC 801-3)	V/m	10					
Protection system (according to DIN 40050, IEC 529)		IP65					
Materials used for outer surfaces		1.4301					
Weight (with cable socket plugged in)	kg, c.	0.19					

Output characteristics		P15RVA1		P15RVA2	
Output range	V	0...10 ± 0.2		mA	4...20 ± 0.4
Zero signal	V	0.4 ± 0.3		mA	4 ± 0.4
Temperature coefficient of zero signal per 10 K in rated temperature range	%	< ± 1; typically. ± 0.5		%	< ± 1; typically. ± 0.5
Temperature coefficient of output range per 10 K in rated temperature range	%	< ± 0.5; typically. ± 0.2		%	< ± 0.5; typically. ± 0.3
Characteristic curve deviation, Initial setting	%	< ± 1; typically. ± 0.5		%	< ± 1; typically. ± 0.5
Highest measurement frequency (-3 dB)	kHz	2		Hz	500
<b>Auxiliary energy</b>					
Supply voltage rated range	V	18...30		V	7...30
Reference voltage	V	24		V	24
Effect of supply voltage when changed from 7 V to 30 V on the zero signal , on the characteristic value		-		% %	0.3 0.3
Effect of supply voltage when changed from 18 V to 30 V on the zero signal , on the characteristic value	% %	0.3 0.3			-
Maximum load resistance	kΩ	10			-
Apparent ohmic resistance		-		kΩ	< 1.1 <sup>1)</sup>
Maximum current consumption	mA	30		mA	100

<sup>1)</sup> Dependent on the supply voltage

Modifications reserved.  
All details describe our products in general form only. They are not to be understood as express warranty and do not constitute any liability whatsoever.

**Hottinger Baldwin Messtechnik GmbH**

Postfach 10 01 51, D-64201 Darmstadt  
Im Tiefen See 45, D-64293 Darmstadt  
Tel.: +49/61 51/ 8 03-0; Fax: +49/61 51/ 8039100  
E-mail: support@hbm.com www.hbm.com



measurement with confidence