

T10FM

Torque Flange



Special features

- Nominal (rated) torque:
15 kN·m, 20 kN·m, 25 kN·m,
30 kN·m, 40 kN·m, 45 kN·m,
50 kN·m, 60 kN·m, 70 kN·m and
80 kN·m
- Nominal (rated) rotational speed
from 3000 rpm to 8000 rpm
- Short design
- High permissible transverse
forces
- High radial stiffness
- Contactless
- Integral speed measuring
system (optional)

Installation example

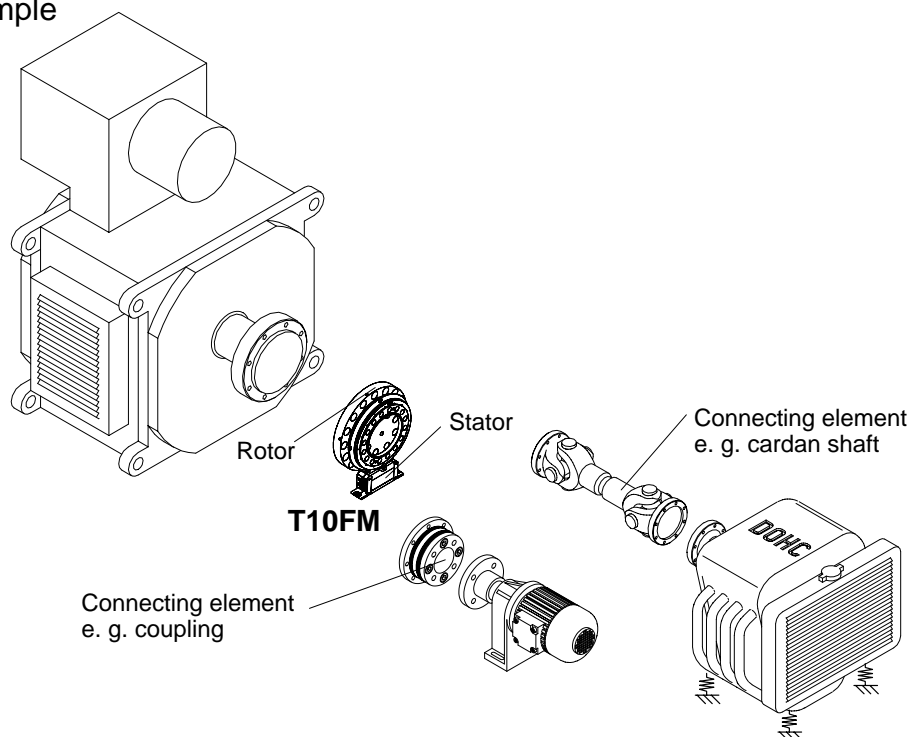

Specifications

Type	T10FM										
Accuracy class	0.1										
Torque measuring system											
Nominal (rated) torque M_{nom} for reference only	kN·m kft·lb	15 11.25	20 15	25 18.75	30 22.5	40 30	45 33.75	50 37.5	60 45	70 52.5	80 60
Nominal (rated) sensitivity (range between torque = zero and M_{nom})											
Frequency output	kHz	5									
Voltage output	V	10									
Characteristic tolerance (deviation of the actual frequency span at M_{nom} from the nominal (rated) sensitivity)											
Frequency output	%	± 0.2									
Voltage output	%	± 0.3									
Output signal at torque = zero											
Frequency output	kHz	10									
Voltage output	V	0									
Nominal (rated) output signal											
Frequency output with positive nominal (rated) torque	kHz	15 (± 5 V symmetric) ¹⁾ / 15 (12 V asymmetric)									
Frequency output with negative nominal (rated) torque	kHz	5 (± 5 V symmetric) ¹⁾ / 5 (12 V asymmetric)									
Voltage output with positive nominal (rated) torque	V	+10									
Voltage output with negative nominal (rated) torque	V	-10									
Limit load resistance											
Frequency output	kΩ	> 2									
Voltage output	kΩ	> 5									
Long-term drift over 48 h											
Voltage output	mV	< ± 3									
Cut-off frequency											
Voltage output -3 dB	kHz	1									
Group delay time											
Frequency output	ms	0.15									
Voltage output	ms	0.9									
Residual ripple											
Voltage output	mV	40 (Peak/Peak)									
Temperature influence per 10 K in the nominal (rated) temperature range on the output signal, related to the actual value of signal span											
Frequency output	%	< ± 0.1									
Voltage output	%	< ± 0.2									
on the zero signal, related to the nominal (rated) sensitivity											
Frequency output	%	< ± 0.05									
Voltage output	%	< ± 0.15									
Maximum modulation range											
Frequency output	kHz	4 ... 16									
Voltage output	V	-10.5 ... +10.5									
Power supply											
Nominal (rated) supply voltage (protective low voltage)	V (DC)	18 ... 30; asymmetric									
Current consumption											
in measuring mode	A	< 0.9									
in start-up mode	A	< 2									
Nominal (rated) power consumption	W	< 12									

1) RS-422 complementary signals, factory setting

Specifications (Continued)

Nominal (rated) torque M_{nom} for reference only	kN·m kft·lb	15 11.25	20 15	25 18.75	30 22.5	40 30	45 33.75	50 37.5	60 45	70 52.5	80 60
Linearity deviation including hysteresis, related to the nominal (rated) sensitivity											
Frequency output	%	< ± 0.1 (< ± 0.05 optional)									
Voltage output	%	< ± 0.1 (< ± 0.05 optional)									
Rel. standard deviation of the repeatability, according to DIN1319, by reference to variation of the output signal	%										
Frequency output	%	< ± 0.02									
Voltage output	%	< ± 0.03									
Calibration signal		approx. 50 % of M_{nom} ; value given to the identification plate									
Tolerance of calibration signal related to M_{nom}	%	< ± 0.05									
Speed measuring system											
Measuring system		optical, by means of infrared light and metallic slotted disc									
Mechanical increments	Number	720									
Positional tolerance of the increments	mm	± 0.05									
Tolerance of the slot width	mm	± 0.05									
Pulses per rotation (electrically adjustable)	Number	720 ¹⁾ ; 360; 180; 90; 60; 30; 15									
Output signal	V	5 ²⁾ symmetric; 2 square wave signals approx. 90° phase shifted									
Minimum speed for sufficient pulse stability	rpm	2									
Group delay time	µs	< 5 (typ. 2.2)									
Hysteresis of reversing the direction of rotation³⁾ with relative vibrations between rotor and stator											
Torsional vibrations of the rotor	Degree	< approx. 2									
Horizontal vibration amplitudes of the stator	mm	< approx. 2									
Load resistance	kΩ	≥ 2 (regard to terminating resistances according RS-422)									
Permitted degree of soiling, in the optical path of the sensor fork (lenses, slotted disc)	%	< 50									
Protection against scattered light		by fork and infrared filter									
General data											
EMC											
EME (Emission according to EN61326-1, table 4)											
RFI field strength	-	Class B									
Immunity from interference (EN61326-1, table A.1)											
Electromagnetic field AM	V/m	10									
Magnetic field	A/m	30									
(ESD)											
Contact discharge	kV	4									
Air discharge	kV	8									
Burst	kV	1									
Surge	kV	1									
Line-conducted disturbance (AM)	V _{pp}	3									
Degree of protection according to EN 60529	-	IP 54									
Weight, approx.											
Rotor	kg	26			45			60			
Stator	kg	1.4									

¹⁾ Factory settings

²⁾ RS-422 complementary signals

³⁾ Can be switched off

Specifications (Continued)

Nominal (rated) torque M_{nom} for reference only	kN·m kft·lb	15 11.25	20 15	25 18.75	30 22.5	40 30	45 33.75	50 37.5	60 45	70 52.5	80 60
Reference temperature	°C [°F]	+23 [73.4]									
Nominal (rated) temperature range	°C [°F]	+10 ... +60 [+50 ... +140]									
Service temperature range	°C [°F]	-10 ... +60 [+14 ... +140]									
Storage temperature range	°C [°F]	-20 ... +70 [-4 ... +158]									
Impact resistance , test severity level to IEC 68-2-27-1987											
Number of impacts	n	1000									
Duration	ms	3									
Acceleration (half-sine)	m/s ²	650									
Vibration resistance , test severity level to IEC 68-2-6-1982											
Frequency range	Hz	5 ... 65									
Duration	h	1.5									
Acceleration (amplitude)	m/s ²	50									
Nominal (rated) rotational speed	rpm	6000			4000			3000			
Nominal (rated) rotational speed optional	rpm	8000			6000			4500			
Load limits⁴⁾											
Limit torque	kN·m	32			60			110			
Breaking torque	kN·m	> 50			> 90			> 160			
Axial limit force	kN	60			120			240			
Lateral limit force	kN	80			160			240			
Bending limit moment	N·m	6000			12000			24000			
Oscillation bandwidth according to DIN 50100 (peak-to-peak)	kN·m	25			45			80			
upper maximum torque	kN·m	+ 20			+ 40			+ 70			
lower maximum torque	kN·m	- 20			- 40			- 70			
Mechanical data											
Torsional stiffness c_T	kN·m/rad	14500			34000			60000			
Torsion angle M_{nom}	degree	0.06	0.08	0.1	0.05	0.065	0.075	0.05	0.06	0.07	0.08
Axial stiffness c_a	kN/mm	1250			1500			2200			
Radial stiffness c_r	kN/mm	1800			2500			3600			
Stiffness with bending moment about a radial axis c_b	kN·m/rad	3300			7400			14800			
Maximum excursion at axial limit force	mm	< 0.05			< 0.08			< 0.12			
Additional max. concentricity error at lateral limit force	mm	< 0.05			< 0.07			< 0.1			
Additional plane-parallel deviation at bending limit moment	mm	0.5									
Balance quality-level to DIN ISO 1940		G 6.3									
Max. limits for relative shaft vibration (peak-to-peak)⁵⁾	µm				$s_{max} = \frac{4500}{\sqrt{n}}$			(n in rpm)			
Mass moment of inertia of the rotor L_V (about axis of rotation)	kg·m ²	0.3			0.7			1.1			
Proportional mass moment of inertia (Flange A)	%	70									
Max. permissible static eccentricity of the rotor (radially)											
without speed measuring system	mm	± 2									
with speed measuring system	mm	± 1									
Permissible axial displacement between rotor and stator											
without speed measuring system	mm	± 3									
with speed measuring system	mm	± 2									

⁴⁾ Each type of irregular stress can only be permitted with its given static limit values (bending moment, lateral or axial load, exceeding the nominal (rated) torque) if none of the others can occur. Otherwise the limit values must be reduced. If for instance 30 % of the bending limit moment and also 30 % of the lateral limit force are present, only 40 % of the axial limit force are permitted, provided that the nominal (rated) torque is not exceeded.

With the permitted bending moments, axial, and lateral limit forces, measuring errors of about 1 % of the nominal (rated) torque can occur. If the nominal (rated) torque has been exceeded, the signal output electronics' maximum modulation range must be taken into account.

⁵⁾ Relative undulations within the range of the connecting flanges in accordance with DIN 45670/VDI 2059

Dimensions T10FM without speed measuring system

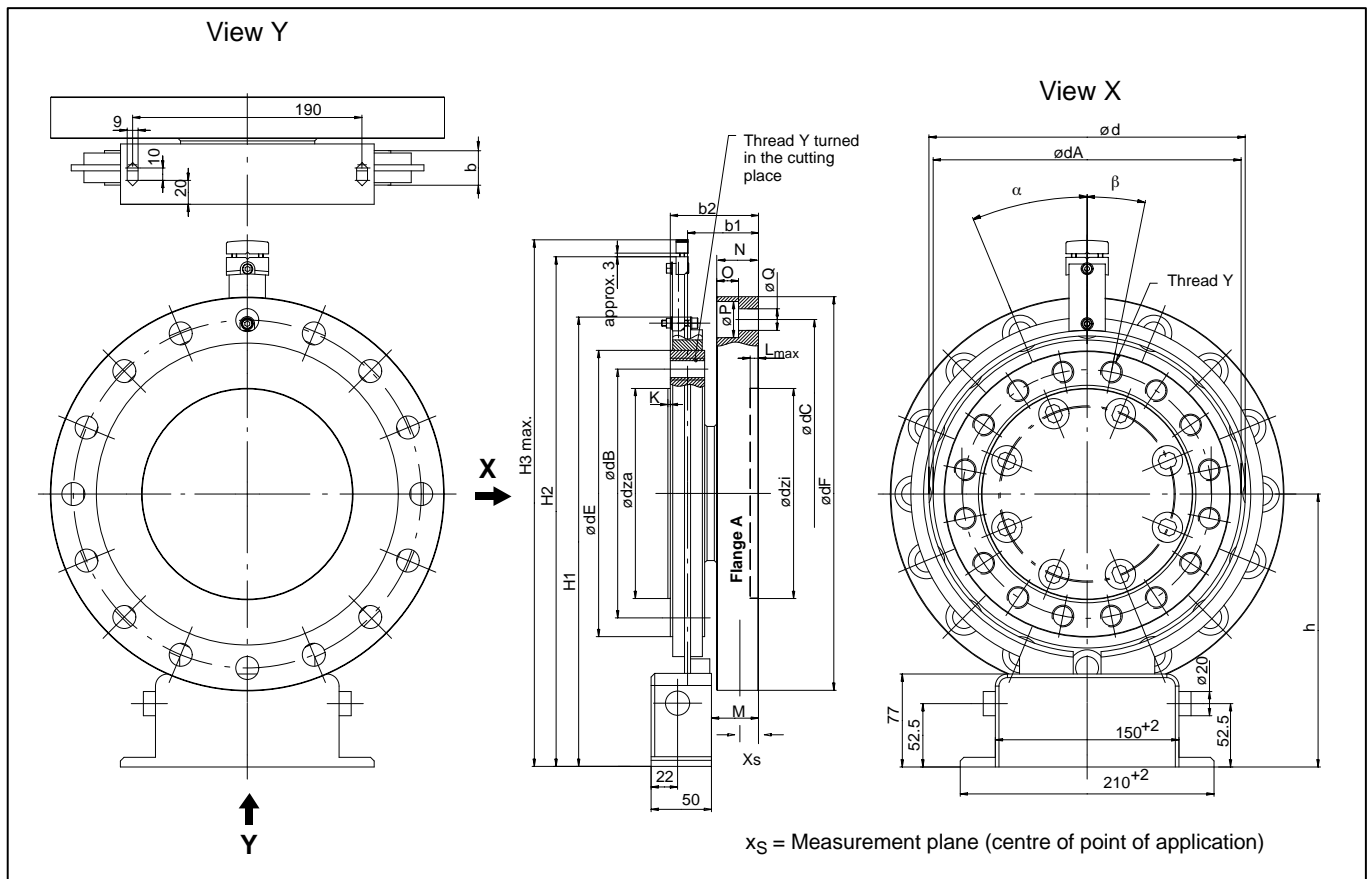

Measuring range (kN·m)	Dimensions in mm														
	h	H1	H2	H3	b	b1	b2	Ød	ØdA	ØdB	ØdC	ØdE	ØdF	Ødza	K
15															
20	226.5	373	423	437	28.5	59	73	262	256	206	288	237.15	326	174 _{g5}	3
25															
30															
40	248	416	466	480	35	69	85	305	299	250	350	280.15	390	210 _{g5}	4
45															
50															
60															
70	263	446	495	509	40	74	95	335	329	275	385	310.15	425	240 _{g5}	4
80															

Measuring range (kN·m)	Dimensions in mm										
	Ødzi	L _{max}	M	N	O	P	Q	X _S	α	β	Y
15											
20	174 ^{H6}	4	38	34.5	19.5	30	19	24	22.5°	11.25°	M18 x 2.5
25									16x22.5°=360°	16x22.5°=360°	
30											
40	210 ^{H6}	4	44	40	21.5	33	21	26	15°	15°	M20 x 2.5
45									24x15°=360°	24x15°=360°	
50											
60	240 ^{H6}	4	49	45	23.5	36	23	29	15°	15°	M22 x 2.5
70									24x15°=360°	24x15°=360°	
80											

Dimensions T10FM with speed measuring system

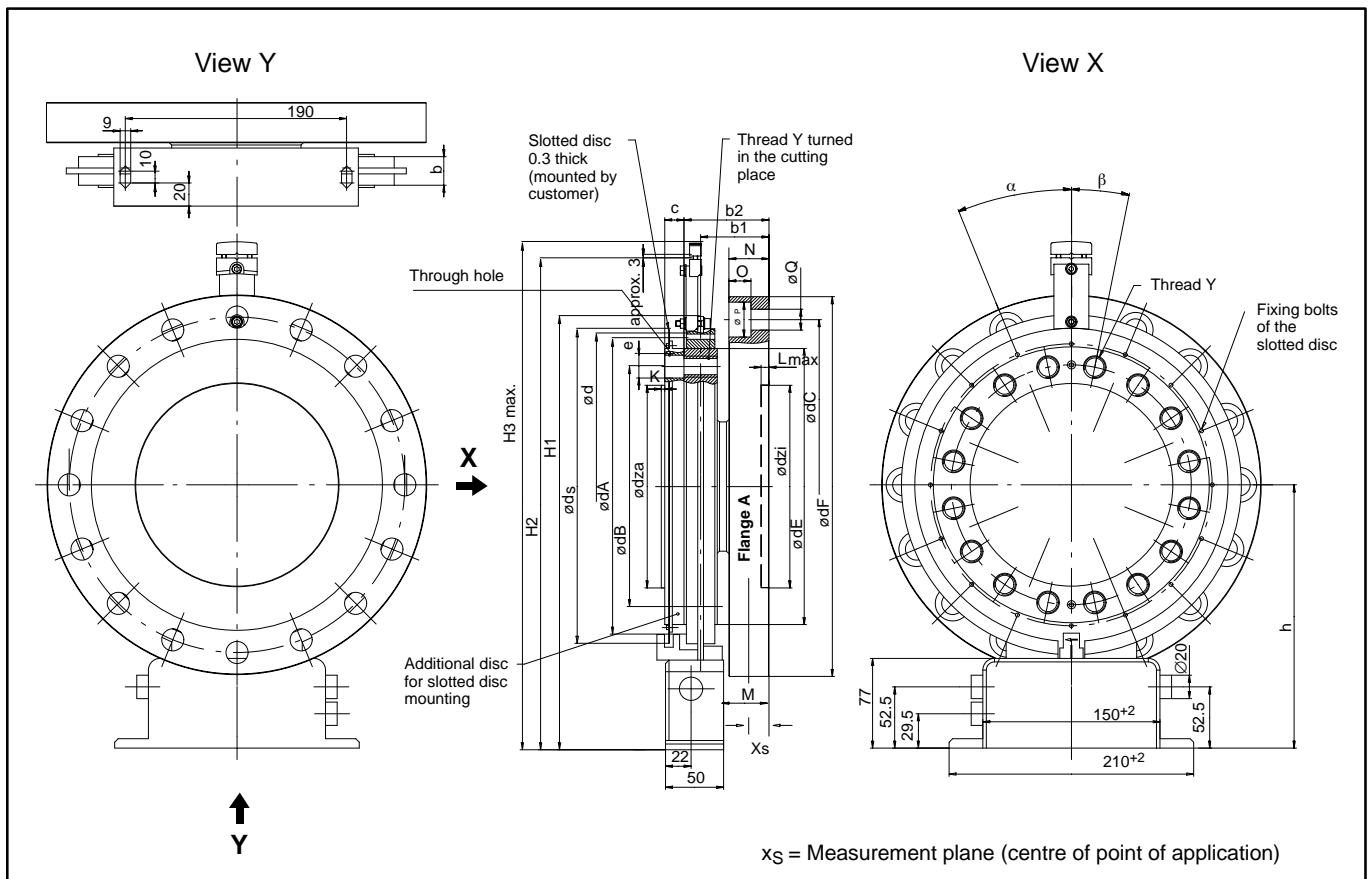

Measuring range (kN-m)	Dimensions in mm																
	h	H1	H2	H3	b	b1	b2	$\varnothing d$	$\varnothing dA$	$\varnothing dB$	$\varnothing dC$	$\varnothing dE$	$\varnothing dF$	$\varnothing dza$	K	$\varnothing dzi$	L_{max}
15																	
20	226.5	373	423	437	28.5	59	73	262	256	206	288	237.15	326	174 _{g5}	3	174 ^{H6}	4
25																	
30																	
40	248	416	466	480	35	69	85	305	299	250	350	280.15	390	210 _{g5}	4	210 ^{H6}	4
45																	
50																	
60	263	446	495	509	40	74	95	335	329	275	385	310.15	425	240 _{g5}	4	240 ^{H6}	4
70																	
80																	

Measuring range (kN-m)	Dimensions in mm												
	$\varnothing d_s$	c	e	M	N	O	P	Q	x_s	α	β	Y	
15													
20	269	16.5	19.5	38	34.5	19.5	30	19	24	22.5°	11.25°	M18 x 2.5	
25										16x22.5°=360°	16x22.5°=360°		
30													
40	312	14.5	21.5	44	40	21.5	33	21	26	15°	15°	M20 x 2.5	
45										24x15°=360°	24x15°=360°		
50													
60	342	9.5	23.5	49	45	23.5	36	23	29	15°	15°	M22 x 2.5	
70										24x15°=360°	24x15°=360°		
80													

Flatness and concentricity tolerances

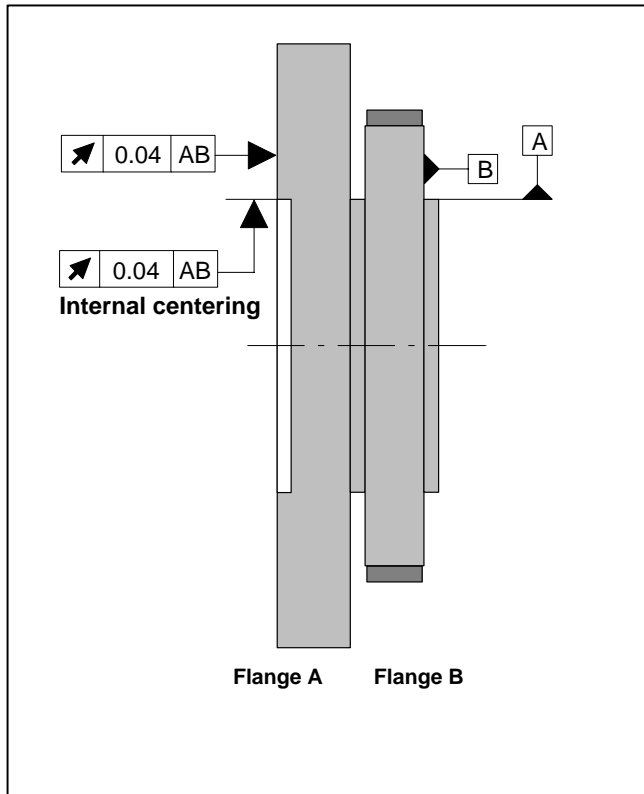

Area free of metal parts

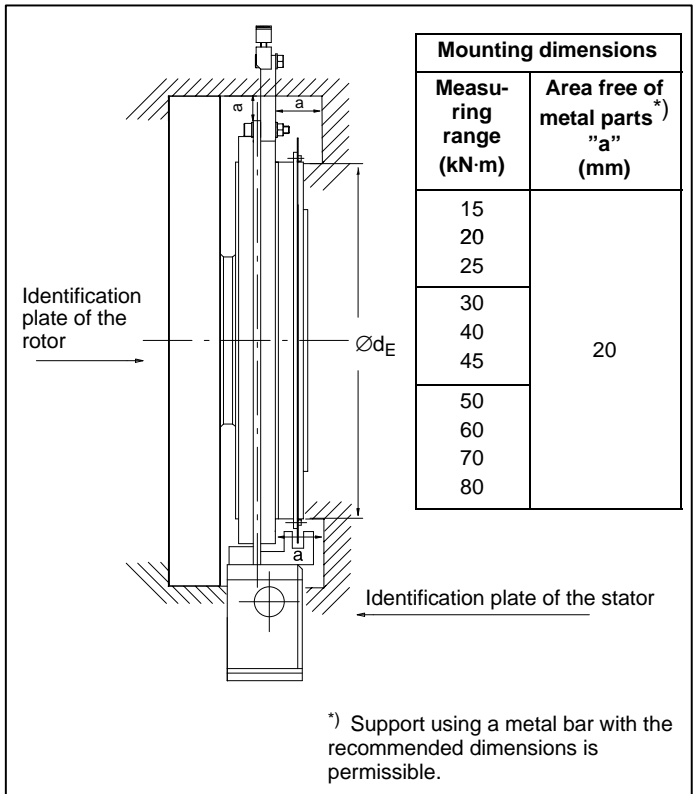

Screw fitting of the rotor

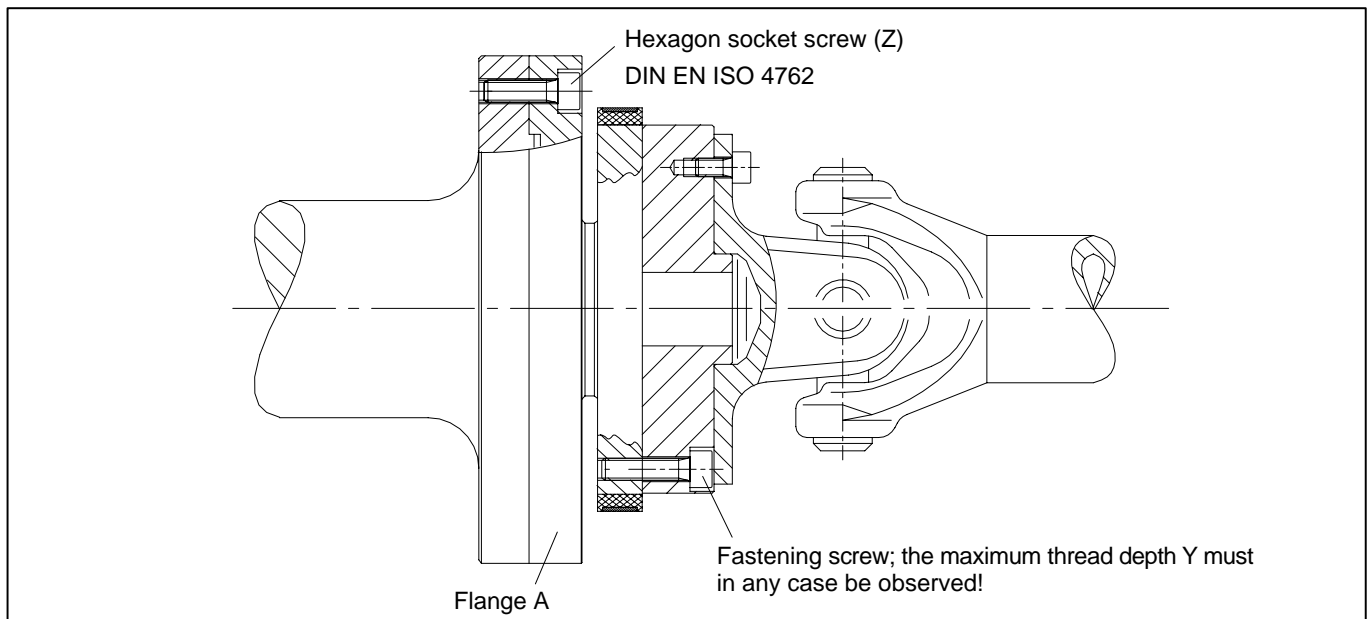

Measuring range (N·m)	Fastening screws (Z) ¹⁾	Fastening screws class	Maximum thread depth (Y) (mm)	Prescribed fastening torque (N·m)
15/20/25	M18x2.5	10.9	30	400
30/40/45	M20x2.5		40	560
50/60/70/80	M22x2.5		45	760

¹⁾ DIN EN ISO 4762; bk/oiled/ $\mu_{tot}=0.125$

Ordering number

Code	Option 1: Measuring range
015R	15 kN·m
020R	20 kN·m
025R	25 kN·m
030R	30 kN·m
040R	40 kN·m
045R	45 kN·m
050R	50 kN·m
060R	60 kN·m
070R	70 kN·m
080R	80 kN·m

Code	Option 4: Speed measuring system
0	Without speed measuring system
1	With speed measuring system

Code	Option 2: Electrical configuration
SU2	Output signal 10 kHz \pm 5 kHz and \pm 10 V, Supply voltage 18...30 V DC

Code	Option 3: Accuracy
S	Linearity deviation including hysteresis $< \pm 0,1$ %
G	Linearity deviation including hysteresis $< \pm 0,05$ %

Code	Option 5: Customer-specific modification
S	None
H	Higher nominal (rated) rotational speed, depending on measuring range 4500 min ⁻¹ up to 8000 min ⁻¹

Ordering number:

K-T10FM - [] - [] - [] - [] - []

Ordering example:

K-T10FM - 0 5 0 R - S U 2 - S - 0 - S

Accessories, to be ordered separately:

1-KAB149-6, connecting cable torque, 423-D-Sub 15P, 6 m

1-KAB150-6, connecting cable speed, 423-D-Sub 15P, 6 m

1-KAB153-6, connecting cable torque, 423-free-ends, 6 m

1-KAB154-6, connecting cable speed, 423-free-ends, 6 m

423G-7S cable socket, 7-pole, straight cable entry, for torque output (connector 1, 3), order no. 3-3101.0247

423W-7S cable socket, 7-pole, 90° cable entry, for torque output (connector 1, 3), order no. 3-3312.0281

423G-8S cable socket, 8-pole, straight cable entry, for speed output (connector 2), order no. 3-3312.0120

423W-8S cable socket, 8-pole, 90° cable entry, for speed output (connector 2), order no. 3-3312.0282

Raw cable Kab8/00-2/2/2, order no. 4-3301.0071

Modifications reserved.

All details describe our products in general form only. They are not to be understood as express warranty and do not constitute any liability whatsoever.

Hottinger Baldwin Messtechnik GmbH

Im Tiefen See 45, D-64293 Darmstadt, Germany

Tel.: +49 6151 8030; Fax: +49 6151 803 9100

E-mail: support@hbm.com www.hbm.com



measurement with confidence