

# C6A

## Force Transducer



### Special features

- Compressive force transducer
- Nominal forces 200 kN ... 5 MN
- Continuous inner bore for nominal forces from 200 kN to 2 MN
- Rust-resistant version for 200 kN and 500 kN nominal forces
- Extensive mounting accessories

Dimensions (in mm; 1 mm= 0.03937 inches)

**C6A<sup>1)</sup>**, nominal forces 200 kN...2 MN

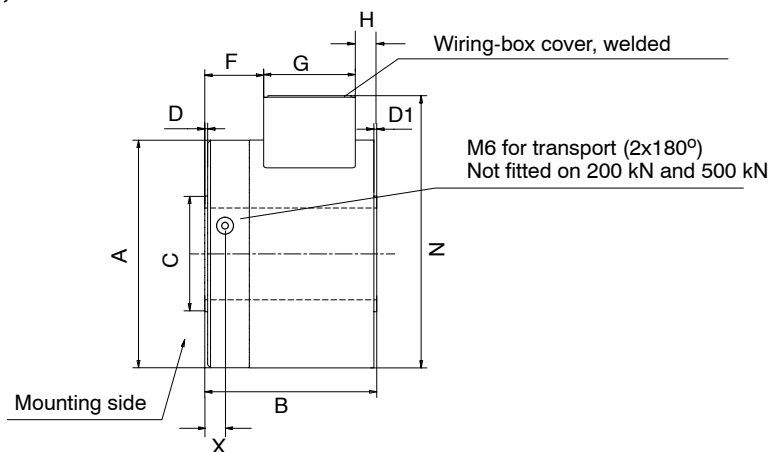

Cable:  $\varnothing$  6,5 mm; 6 m long, shielded, unterminated

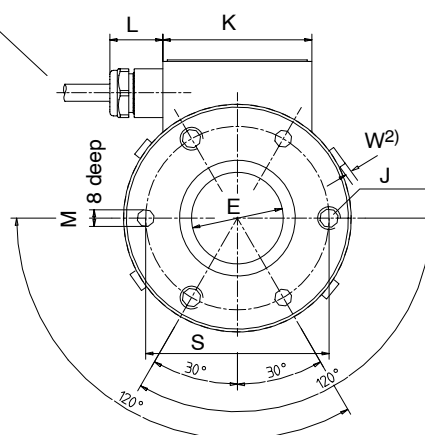

1) Force transducers for nominal loads  $\leq 500$  kN, manufactured from rust-resistant material

2) For 1 MN and 2 MN only

Nominal forces	A	B	C $\pm 0.1$	D	D1	E $^{+0.1}$	F	G	H	J	K	L	M <sup>H11</sup>	N	S $\pm 0.1$	W	X
200 kN	80	60	40.4	1	1	32	19.5	32.5	8	M8-8 deep	53	18.5	6	97.5	64	-	-
500 kN	80	60	52	1	1	32	19.5	32.5	8	M8-8 deep	53	18.5	6	97.5	64	-	-
1 MN	168	100	88	2	3	68	29	43	28	M12-15 deep	50	35	8	200	130	1	10
2 MN	168	100	106	2	3	68	29	43	28	M12-15 deep	50	35	8	200	130	1	10

## Dimensions continued (in mm)

### C6A, nominal force 5 MN

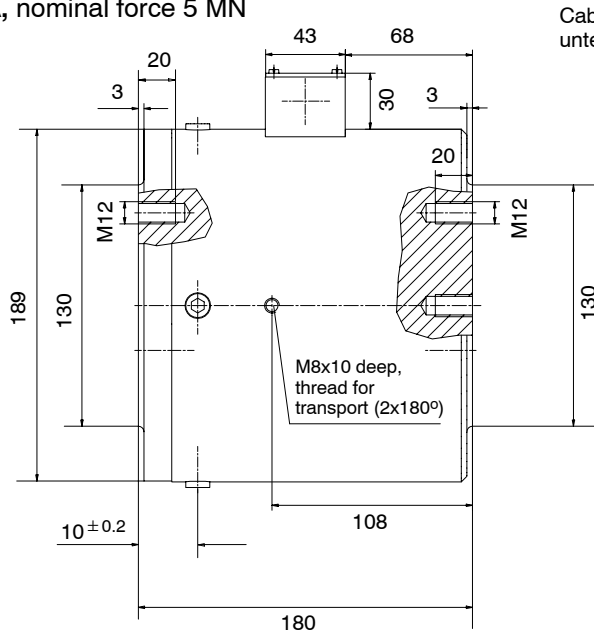

Cable: Ø6.5 mm; 6 m long, shielded, untermiated

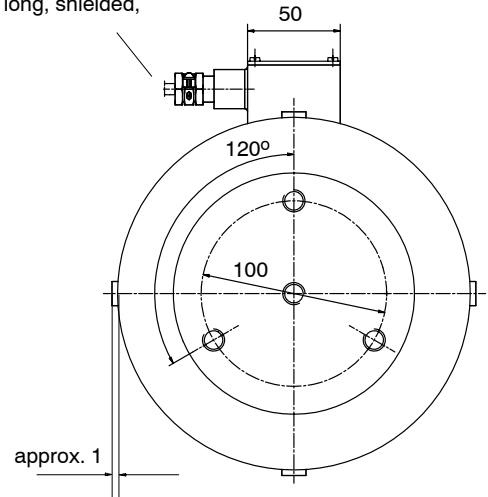

## Mounting accessories

### Spherical cap ZK (Compensation by oblique load introduction)

for nominal forces in range 200 kN...2 MN

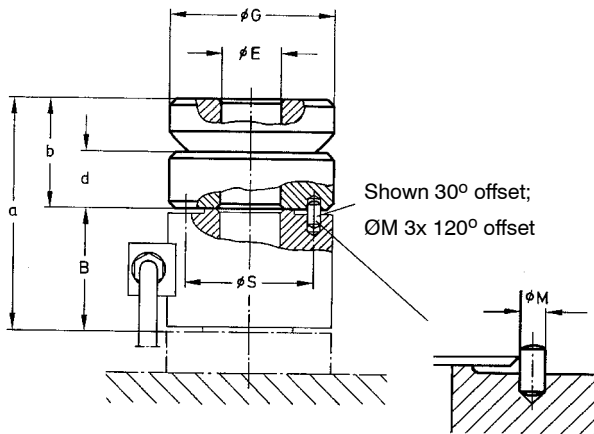

for 5 MN nominal forces

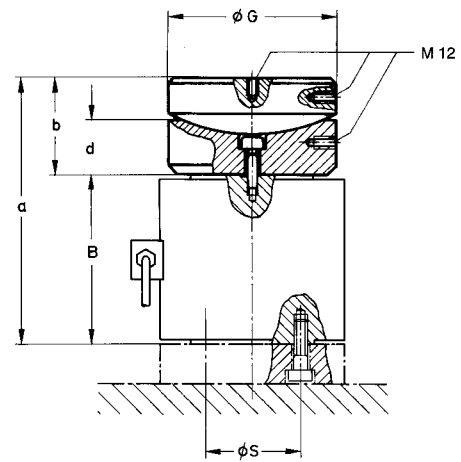

Nominal forces	ZK order no.	Weight in kg	B	E <sup>+0.1</sup>	G	M <sub>h11</sub>	s	a	b	d
200...500 kN	1-C6/50T/ZK	1.7	60	32	82 <sub>-0.2</sub>	6	64 ± 0.1	112	52	28
1 MN	1-C6/100T/ZK	3.8	100	68	121.5 <sub>-0.2</sub>	8	130 ± 0.1	175	74.5	40
2 MN	1-C6/200T/ZK	11.6	100	68	159 <sub>-0.2</sub>	8	130 ± 0.1	195	95	50
5 MN	1-C6/500T/ZK	20.6	180	-	178 <sub>-0.3</sub>	-	100	284	103	61

## Mounting accessories continued

### Load button ZL (for high-precision measurement)

for nominal forces in range 200 kN... 2 MN

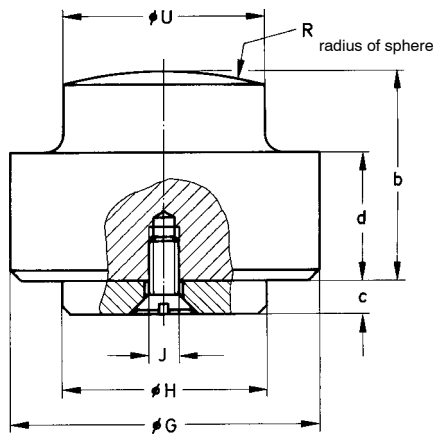

for 5 MN nominal forces

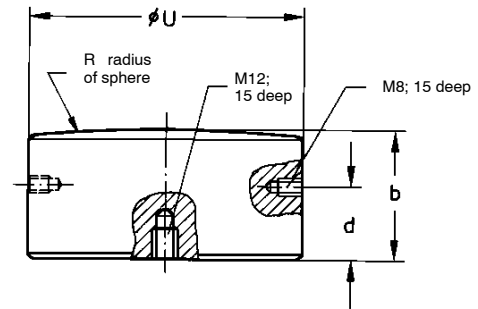

Nominal forces	ZL order no.	Weight in kg	G	H <sub>-0.1</sub>	J	R	U <sub>-0.2</sub>	b	c	d
200 kN	1-C6/20T/ZL	0.8	60	31.9	M5	300	32	45	5	30
500 kN	1-C6/50T/ZL	0.8	60	31.9	M5	300	44	45	5	30
1 MN	1-C6/100T/ZL	6.4	120	67.9	M6	600	64	80	8	60
2 MN	1-C6/200T/ZL	6.8	120	67.9	M6	600	85	80	8	60
5 MN	1-C6/500T/ZL	6.5	-	-	-	-	129.8 <sub>-0.05</sub>	60	-	35

### Pendle bearing support EPO3 (Compensation and oblique setting by displacement of the load introduction)

Consisting of 2x EPO3 and 2x ZL and 1x C6A force transducers

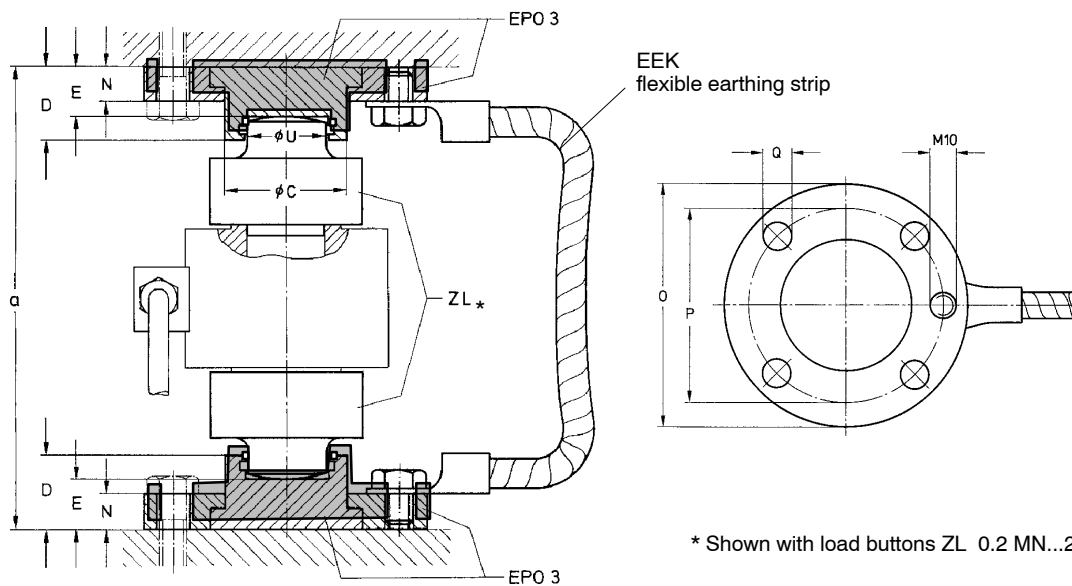

\* Shown with load buttons ZL 0.2 MN...2 MN

Nominal forces	EPO3 order no.	Weight in kg	C	D	E	N	O	P	Q	U <sub>-0.2</sub>	a
200 kN	1-EPO3R/20T	1.2	47.9	28	20	14	114	90	13	32	190
500 kN	1-EPO3/50T	3.4	81.9	50	39	18	148	120	17	44	228
1 MN	1-EPO3/100T	3.2	81.9	50	39	18	148	120	17	64	338
2 MN	1-EPO3/250T	13.0	139.5	80	67	25	225	190	22	85	394
5 MN	1-EPO3/500T	27.0	169.8	103	90	33	270	220	26	130	480

# Specifications (data according to VDI standards 2638)

Type			C6A				
Accuracy class			0.5				
Nominal force	F <sub>nom</sub>	MN	200 kN	500 kN	1 MN	2 MN	5 MN
Nominal sensitivity	C <sub>nom</sub>	mV/V	2				
<b>Relative sensitivity deviation<sup>2)</sup></b>	d <sub>c</sub>	%					< ± 1
when used with hardened pressure plates		%	< ± 2.5				< ± 1
when used with load button ZL and pendle bearing EPO3		%	< ± 0.5				< ± 0.5
when used with spherical cap ZK		%	< ± 2.5	< ± 4		< ± 0.5	
<b>Relative zero signal deviation</b>	d <sub>s,0</sub>	%	< 1				
<b>Relative range of inversion (0.5F<sub>nom</sub>)</b>	u	%	< ± 0.8				
<b>Linearity deviation<sup>2)</sup></b>	d <sub>lin</sub>	%					
when used with hardened pressure plates		%	< ± 1				< ± 0.5
when used with load button ZL and pendle bearing EPO3		%	< ± 0.5				< ± 0.5
when used with spherical cap ZK		%	< ± 1				< ± 0.5
<b>Effect of temperature on sensitivity/10 K by reference to nominal sensitivity</b>	TK <sub>c</sub>	%	< ± 0.1				
<b>Effect of temperature on zero signal/10 K by reference to nominal sensitivity</b>	TK <sub>0</sub>	%	< ± 0.05				
<b>Creep over 30 min, in nominal temperature range<sup>1)</sup></b>	d <sub>crF+E</sub>	%	< ± 0.06				
<b>Input resistance at reference temperature</b>	R <sub>e</sub>	Ω	> 345				
<b>Output resistance at reference temperature</b>	R <sub>a</sub>	Ω	356 ± 1.5				
<b>Isolation resistance at test voltage 100 V</b>	R <sub>is</sub>	GΩ	> 5 × 10 <sup>9</sup>				
<b>Reference excitation voltage</b>	U <sub>ref</sub>	V	5				
<b>Operating range of the excitation voltage</b>	B <sub>U,GT</sub>	V	0.5 ... 12				
<b>Reference temperature</b>	t <sub>ref</sub>	°C	+23				
<b>Nominal temperature range</b>	B <sub>t,nom</sub>	°C	-10...+70				
<b>Operating temperature range</b>	B <sub>t,G</sub>	°C	-30...+85				
<b>Storage temperature range</b>	B <sub>t,S</sub>	°C	-50...+100				
<b>Maximum operating force<sup>1)</sup></b>	F <sub>G</sub>	%	150				
<b>Limit force<sup>1)</sup></b>	F <sub>L</sub>	%	150				
<b>Breaking force<sup>1)</sup></b>	F <sub>B</sub>	%					
when used with hardened pressure plates		%	> 300				
when used with load button ZL and pendle bearing EPO3		%	> 300				> 200
when used with spherical cap ZK		%	> 200				> 200
<b>Static lateral limit force<sup>1)</sup></b>	F <sub>Q</sub>	%					
when used with hardened pressure plates		%	20				
when used with load button ZL and pendle bearing EPO3		%	20				10
when used with spherical cap ZK		%	10				
<b>Permissible vibration amplitude<sup>1)</sup> to DIN 50 100</b>	F <sub>rb</sub>	%	70				
<b>Nominal displacement without mounting accessories ( ± 15 %)</b>	S <sub>nom</sub>	mm	0.07	0.08	0.09	0.11	0.26
<b>Natural frequency without coupled ground and without mounting accessories</b>	f <sub>G</sub>	kHz	4.5	8	6	7.5	4.3
<b>Weight, without cable</b>		kg	1.4	1.7	10.8	12.2	33
<b>Degree of protection to DIN EN 60 529</b>			IP 67				
<b>Cable length, 6-wire connection</b>		m	6				

1) related to the nominal force

2) the differing tolerances when using different mounting accessoires are due to the transducer's low profile

Modifications reserved.

All details describe our products in general form only. They are not to be understood as express warranty and do not constitute any liability whatsoever.

**Hottinger Baldwin Messtechnik GmbH**

Im Tiefen See 45, D-64293 Darmstadt, Germany

Tel.: +49 6151 8030; Fax: +49 6151 803 9100

E-mail: support@hbm.com www.hbm.com



measurement with confidence