

# KD/STZ/KDB

## Force Transducers



### Special features

- STZ: tensile force transducers  
KD, KDB: compressive force transducers
- Nominal forces 600 kN ... 5 MN
- Standard: 4 full bridges for direct bending moment acquisition
- KD/STZ-specification for material testing machines
- KDB-specification for compression strength testing machines for building materials

Dimensions (in mm; 1 mm= 0.03937 inches)

#### KD 1...2 MN

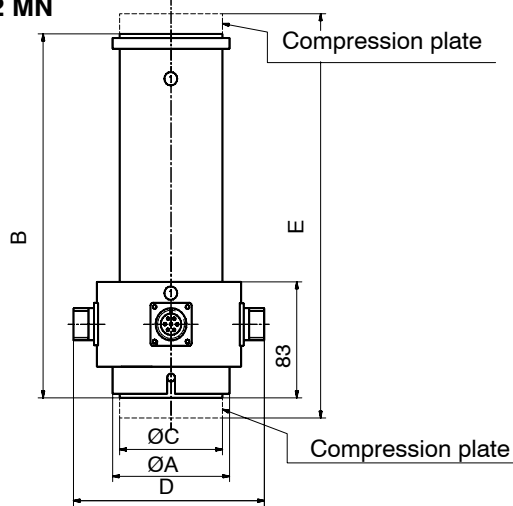

#### KD 3...5 MN

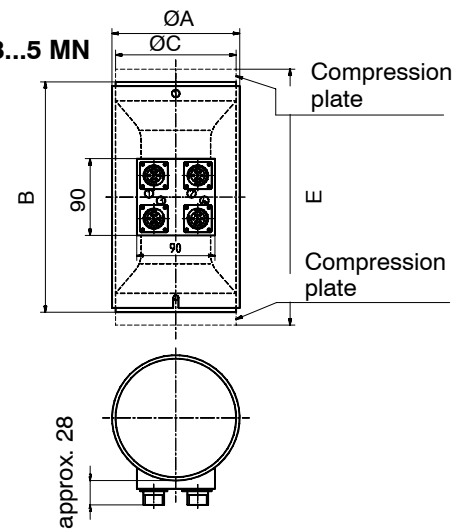

typ. ord.no.	ØA	B	ØC	approx. D	E	Weight
1-KD / 1 MN	91	270	80	155	300	10 kg
1-KD / 2 MN	124	270	113	188	300	18 kg
1-KD / 3 MN	147	270	139	-	320	27 kg
1-KD / 5 MN	189	370	179	-	440	64 kg

# Specifications KD / STZ

Type			KD compression cylinder				STZ tension bar	
Data according to VDI 2638 standards								
Nominal force	$F_{no}$ m	kN	1 000	2 000	3 000	5 000	600	1 000
Class under ISO 376 ( $0.2F_{nom}$ to $F_{nom}$ ) <sup>1)</sup>			0.5					
Nominal sensitivity	$C_{nom}$	mV/V	2.3 to 2.4					
Rel. zero point compensation (zero signal return)	$f_0$	%	< 0.025 (typ. 0.012)					
Relative range ( $0.2F_{nom}$ to $F_{nom}$ ) at unchanged mounting position, typ.	$b_i$	%	0.02					
different mounting positions, typ.	$b$	%	0.07					
Relative range of inversion ( $0.2F_{nom}$ to $F_{nom}$ )	$u$	%	0.13 (typ. 0.07)					
Effect of temperature on sensitivity / 10 K by reference to nominal sensitivity	$TK_C$	%	0.1					
Effect of temperature on the zero signal / 10 K by reference to nominal sensitivity	$TK_0$	%	0.1					
Number of strain gauge full bridges			4					
Input resistance	$R_e$	$\Omega$	$700 \pm 2 \%$					
Isolation resistance	$R_{is}$	$\Omega$	$> 5 \times 10^9$					
Reference excitation voltage	$U_{ref}$	V	5					
Operating range of excitation voltage	$B_{U, G}$	V	0.5 ... 12					
Nominal temperature range	$B_{t, nom}$	$^{\circ}C$	$+10 \dots +40$					
Storage temperature range	$B_{t, S}$	$^{\circ}C$	$-25 \dots +85$					
Reference temperature	$t_{ref}$	$^{\circ}C$	+22					
Max. operational force	( $F_G$ )	%	115					
Weight, approx.		kg	see drawings					
Degree of protection to DIN EN 60529			IP64					
Electrical connection			4 MS3102A16S-1S device boxes					

<sup>1)</sup> Classification can only be obtained in conjunction with a DKD calibration under ISO 376 from HBM

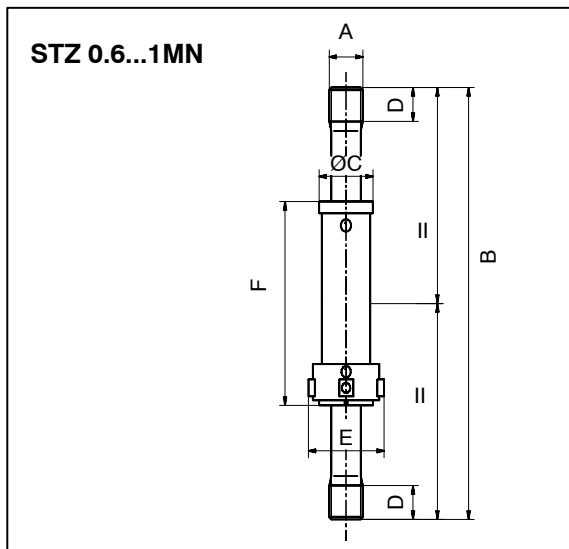

These special KD and STZ transducers are used to check out material testing machines and are designed in accordance to ISO 376. They are compressive force transducers and tensile force transducers that, because of their maximum overall height, are suitable for checking material testing machines according to ISO 7500-1.

The transducers can be used to not only check the force measuring device itself, but also its machine frame under loading. The transducers are therefore each equipped with four SG full bridges, attached around 90° at the circumference of the transducer spring body. In this way, it is possible to determine if the machine frame and the force introduction parts allow the correct, axial stress of a properly installed test specimen.

The transducers are supplied complete with force introduction parts (compression plates or ball cups and ball nuts) as well as a wooden box for storage.

typ. ord.no.	A	B	$\varnothing C$	D	approx. E	F
1-STZ / 0.6 MN	M56x4	650	78,3	40	142	232
1-STZ / 1 MN	M64x4	750	96,3	60	160	240

## Accessories, to be ordered separately:

1-KAB159-5 Connection cable with male connector MS3106PEMV and free ends, length 5 m

## Specifications KDB

Type			KDB
Data according to VDI 2638 standards			
Nominal force	$F_{no}$ m	kN	2000
Class under EN 10002-3 ( $0.2F_{nom}$ to $F_{nom}$ ) <sup>1)</sup>			1
Nominal sensitivity	$C_{nom}$	mV/V	without sensitivity determination
Effect of temperature on sensitivity / 10 K by reference to nominal sensitivity	$T_{KC}$	%	0.1
Effect of temperature on the zero signal / 10 K by reference to nominal sensitivity	$T_{K0}$	%	0.1
Number of strain gauge full bridges			4
Input resistance	$R_e$	$\Omega$	600
Isolation resistance	$R_{is}$	$\Omega$	$> 5 \times 10^9$
Reference excitation voltage	$U_{ref}$	V	5
Operating range of the excitation voltage	$B_{U,G}$	V	0.5 ... 12
Nominal temperature range	$B_{t,nom}$	$^{\circ}C$	+10...+40
Storage temperature range	$B_{t,S}$	$^{\circ}C$	-25...+85
Reference temperature	$t_{ref}$	$^{\circ}C$	+22
Weight, approx.		kg	17
Electrical connection			4 MS3102A16S-1S device boxes

<sup>1)</sup> Classification can only be obtained in conjunction with a DKD calibration under ISO 376 from HBM

Force-proving instrument according to DIN 51302-2, optionally EN 12390-4 for checking compression testing machines for concrete.

The force-proving instrument is designed specifically for the additional checking of compression testing machines for concrete according to ISO 7500-1, Bbl 1.

The special application comprises four full bridges attached around 90° at the circumference of the transducers spring body, thus allowing this transducer to be used for the tests required by the standard.

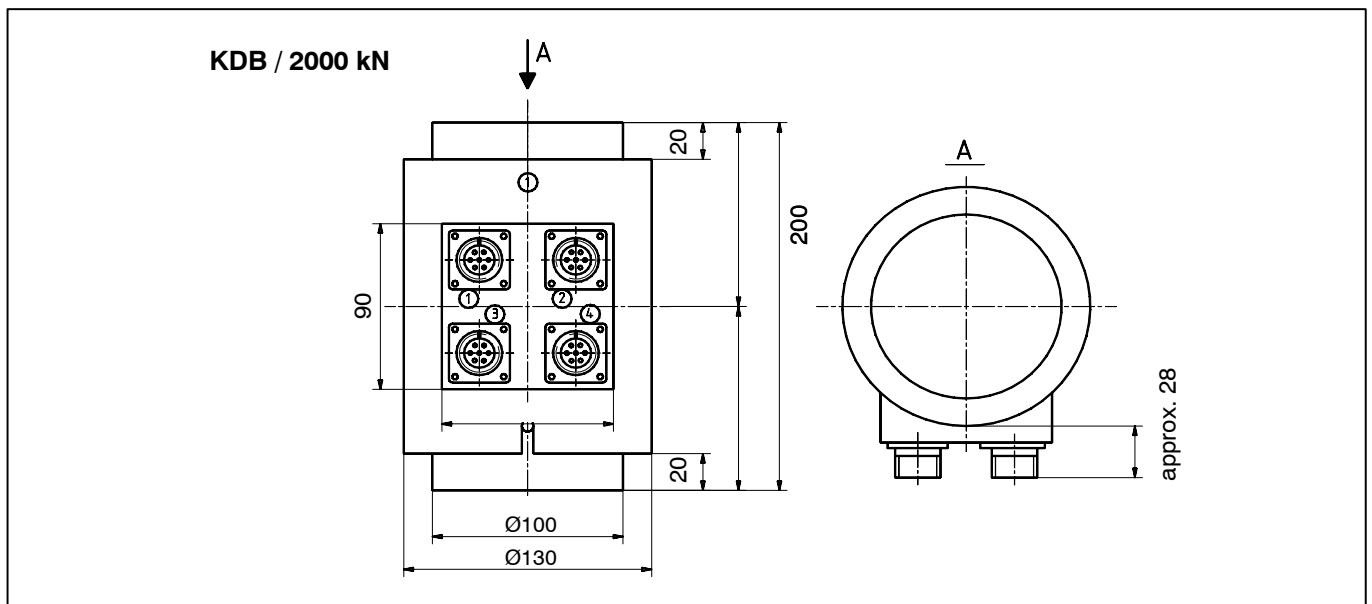

**Accessories**, to be ordered separately:

1-KAB159-5 Connection cable with male connector MS3106PEMV and free ends, length 5 m

## Pin assignment KD/STZ/KDB

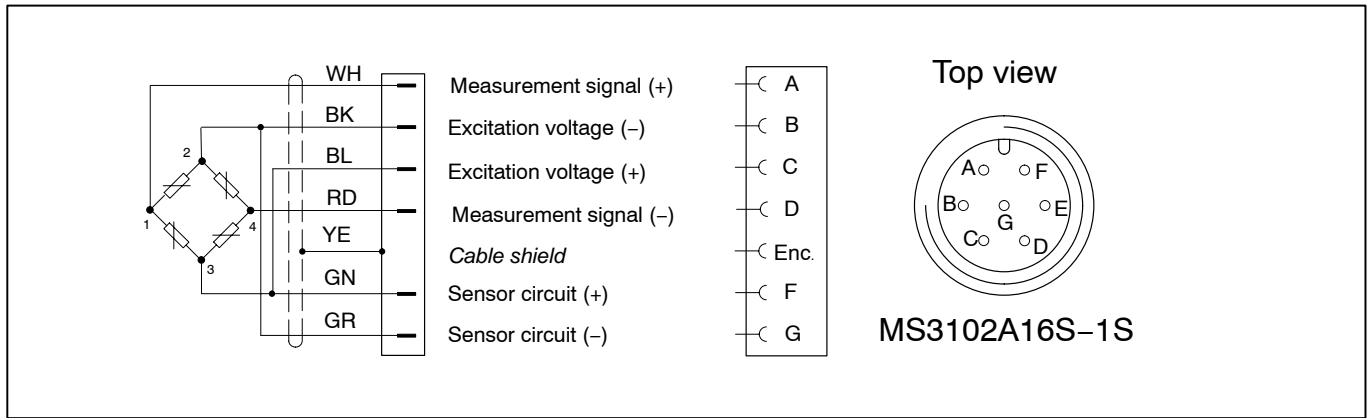

Modifications reserved.

All details describe our products in general form only. They are not to be understood as express warranty and do not constitute any liability whatsoever.

B0856-1.2 en

**Hottinger Baldwin Messtechnik GmbH**

Im Tiefen See 45, D-64293 Darmstadt, Germany  
 Tel.: +49 6151 803-0; Fax: +49 6151 8039100  
 E-mail: support@hbm.com www.hbm.com



measurement with confidence