

S9

Force Transducer

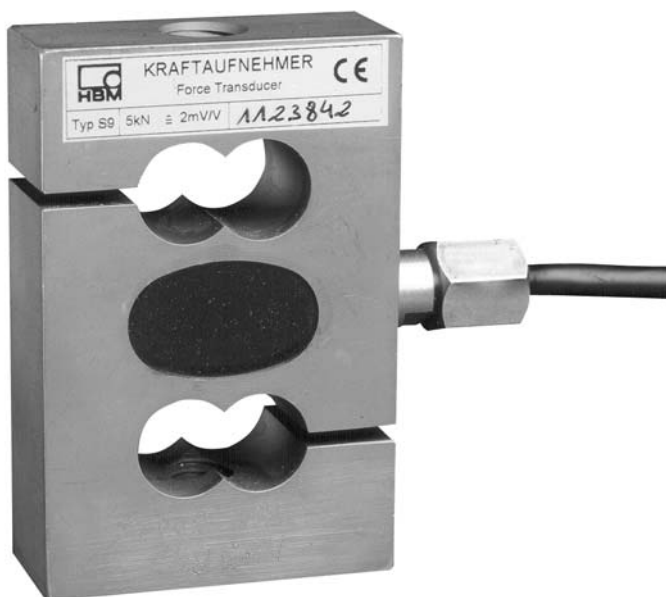

Special features

- Tensile force / compressive force transducer
- Nominal forces 2 kN ... 50 kN
- Accuracy class 0.05
- High transverse force stability

Dimensions (in mm; 1 mm= 0.03937 inches)

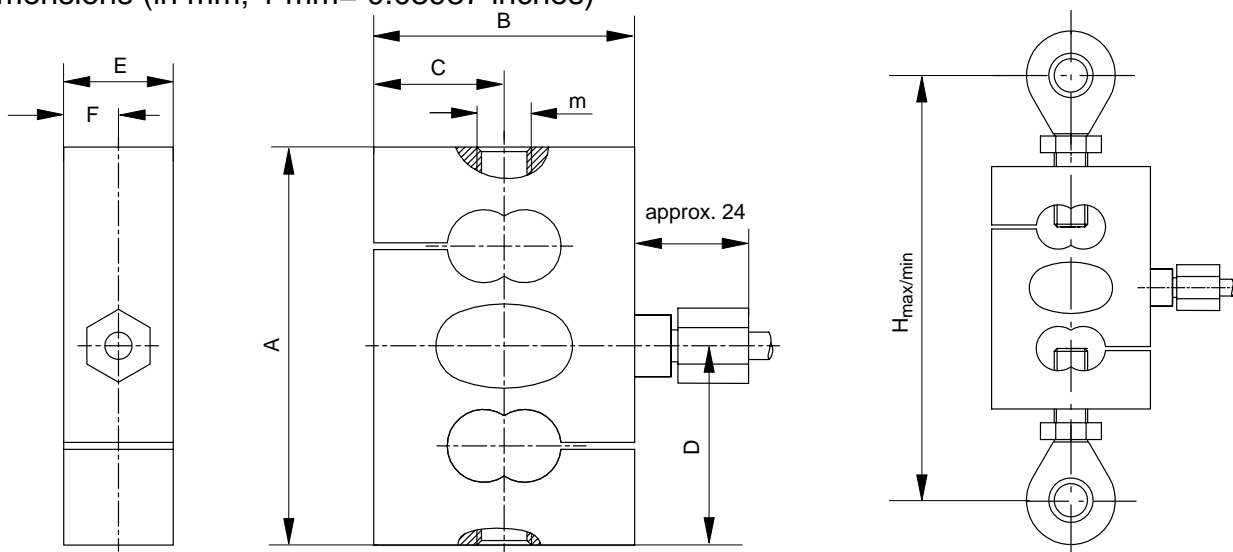

Nominal force (kN)	A	B	C	D	E	F	m	H _{max}	H _{min}
2-10	87.3	57.2	28.6	43.7	24	12	M12	172	153
20	100	69.8	34.9	50	30.2	15.1	M24x2	220	206
50	100	76.2	38.1	50	36.6	18.3	M24x2	260	256

Specifications under VDI 2638

Force transducer type		S9					
Nominal force	F _{nom}	kN	2	5	10	20	50
Accuracy class			0.05				
Nominal sensitivity relative sensitivity deviation tensile/compressive force relative tensile/compressive sensitivity difference relative deviation from zero	C _{nom}	mV/V	2				
	d _c	%	< 0.25				
	d _{zd}	%	< ±0.1				
	d _{s,0}	%	< 5				
	u	%	0.1				
Relative range of inversion (0.2F _{nom} to F _{nom})			0.1				
Linearity deviation		d _{lin}	0.05				
Temperature effect per 10 K by reference to sensitivity to sensitivity to zero signal		TK _c	%				
		TK ₀	%				
Effect of transverse forces (transverse force 10 % F _{nom}) ^{*)}		d _Q	%				
Creep over 30 min.		d _{crF+E}	%				
Input resistance		R _e	Ω				
Output resistance		R _a	Ω				
Isolation resistance		R _{is}	GΩ				
Reference excitation voltage		U _{ref}	V				
Operating range of the excitation voltage		B _{U,G T}	V				
Nominal temperature range		B _{t, nom}	°C [°F]				
Operating temperature range		B _{t, G}	°C [°F]				
Storage temperature range		B _{t, S}	°C [°F]				
Reference temperature		t _{ref}	°C [°F]				
Maximum operating force		(F _G)	%				
Limit force		(F _L)	%				
Breaking force		(F _B)	%				
Limit torque		(M _d)	Nm				
Static lateral limit force*		(F _Q)	%				
Nominal displacement		S _{nom}	mm				
Fundamental resonance frequency		f _G	kHz				
Relative permissible vibrational stress		F _{rb}	%				
Weight			kg				
Degree of protection to DIN EN 60529			IP65				
Cable length, 6-wire connection			m				

*) by reference to a force introduction point on the force-introduction surface

Accessories (option):

Knuckle eye: ZGUW

Dimensions in mm

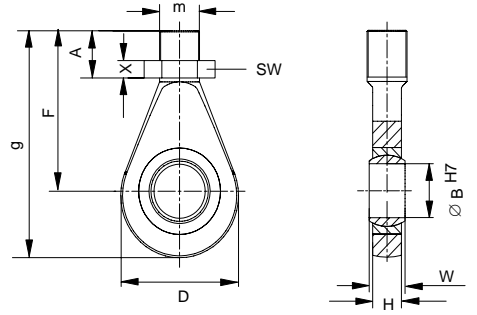

Material: tempering steel, galvanised; rolled steel and PTFE/bronze fabric foil

Nominal force (kN)	Weight [kg]	A	∅B ^{H7}	D	F	g	H	m	X	W	SW
0.5...10	0.1	33.5	12	32	54.5	70.5	12	M12	7	16	19
20...50	0.4	57.5	25	60	94.5	124.5	22	M24x2	10	31	36

Modifications reserved.
All details describe our products in general form only. They are not to be understood as express warranty and do not constitute any liability whatsoever.

Hottinger Baldwin Messtechnik GmbH

Postfach 10 01 51, D-64201 Darmstadt
Im Tiefen See 45, D-64293 Darmstadt
Tel.: +49/61 51/ 8 03-0; Fax: +49/61 51/ 8039100
E-mail: support@hbm.com www.hbm.com



measurement with confidence